

# PARTS FOR MODEL TYPE SQ-1, SQ-H, SQ-HH, OR SQ-HH8

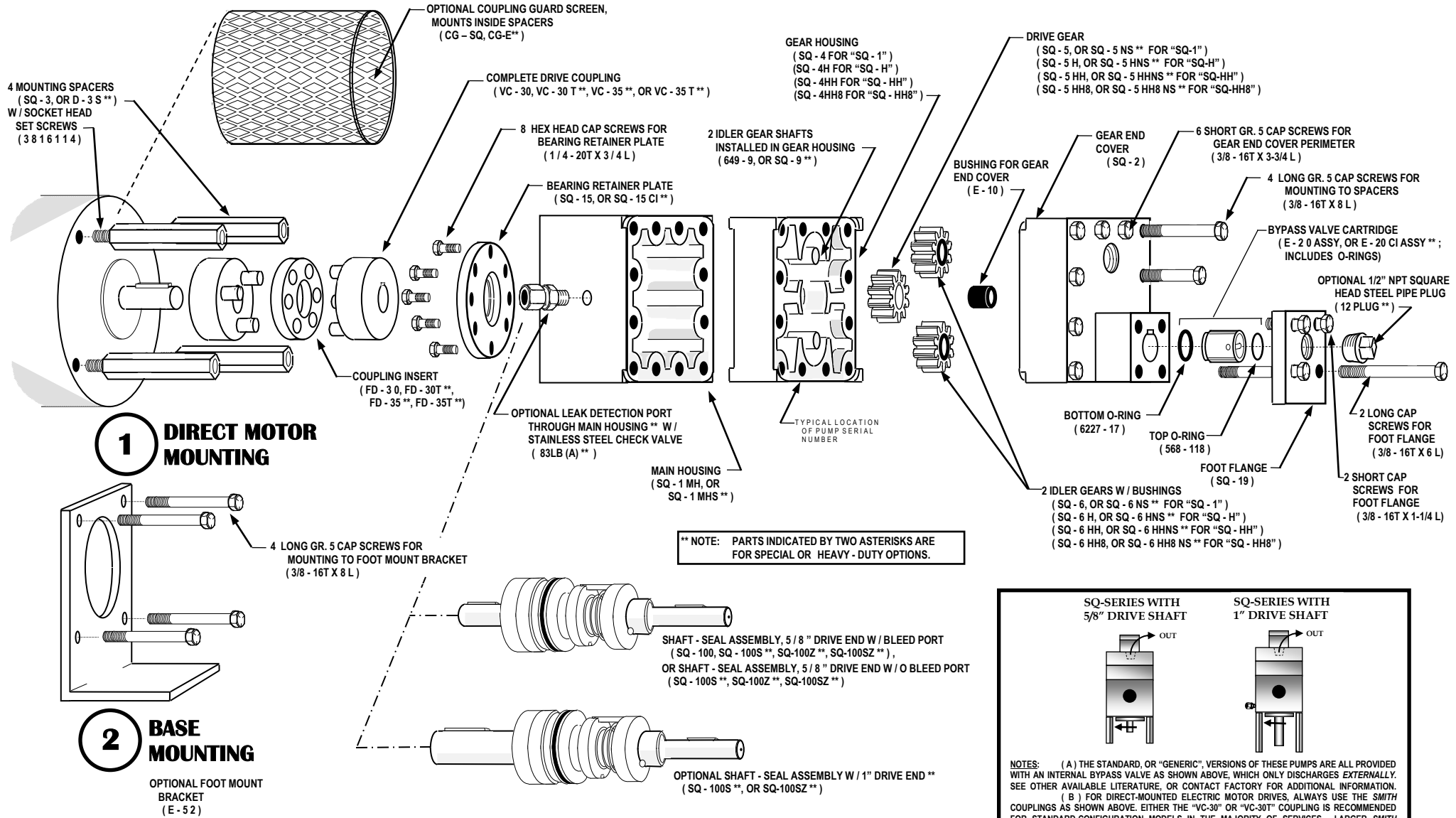

## 1 DIRECT MOTOR MOUNTING

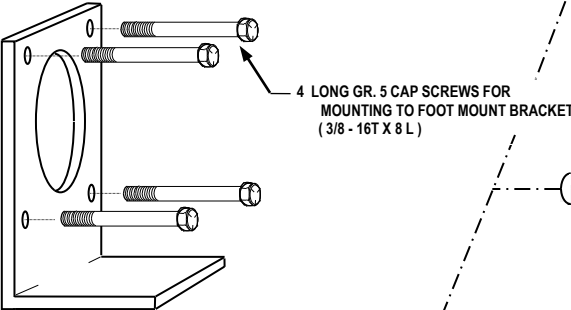

## 2 BASE MOUNTING

OPTIONAL FOOT MOUNT BRACKET (E - 52)

### SMITH PRECISION PRODUCTS COMPANY

P.O. Box 276, Newbury Park, CA 91319 USA  
 1299 Lawrence Drive, Newbury Park, CA 91320 USA  
 Tel.: 805/498-6616 FAX: 805/499-2867  
 e-mail: INFO@smithpumps.com web: www.smithpumps.com



**SQ-SERIES WITH 5/8" DRIVE SHAFT**

**SQ-SERIES WITH 1" DRIVE SHAFT**

**NOTES:** (A) THE STANDARD, OR "GENERIC", VERSIONS OF THESE PUMPS ARE ALL PROVIDED WITH AN INTERNAL BYPASS VALVE AS SHOWN ABOVE, WHICH ONLY DISCHARGES EXTERNALLY. SEE OTHER AVAILABLE LITERATURE, OR CONTACT FACTORY FOR ADDITIONAL INFORMATION. (B) FOR DIRECT-MOUNTED ELECTRIC MOTOR DRIVES, ALWAYS USE THE SMITH COUPLINGS AS SHOWN ABOVE. EITHER THE "VC-30" OR "VC-30T" COUPLING IS RECOMMENDED FOR STANDARD-CONFIGURATION MODELS IN THE MAJORITY OF SERVICES. LARGER SMITH COUPLINGS ARE RECOMMENDED FOR HIGH-TORQUE APPLICATIONS. CONTACT OUR ENGINEERING DEPARTMENT FOR ADDITIONAL INFORMATION. (C) THERE ARE FOUR "SQ-SERIES" MODEL TYPES, ALL OF WHICH ARE REVERSIBLE UNDER SPECIAL CIRCUMSTANCES, WHERE THE INTERNAL BYPASS VALVE IS NOT UTILIZED. THE STANDARD MODEL TYPES ALL HAVE 3/4" FNPT PORTS. THEY CAN ALSO ALL BE PROVIDED WITH AN OPTIONAL 1" FNPT MAIN HOUSING PORT (TOP PORT IN ABOVE SKETCH). TO FACILITATE THE PIPING CONNECTIONS, THE MAIN HOUSING MAY BE ROTATED IN 90° INCREMENTS, WITH RELATION TO THE GEAR END COVER / GEAR HOUSING ASSEMBLY. THESE PUMPS CAN BE READILY MODIFIED FOR USE WITHIN A WIDE VARIETY OF APPLICATIONS. SEE APPROPRIATE LITERATURE, OR CONTACT FACTORY FOR ADDITIONAL INFORMATION ON ALL OF THE AFOREMENTIONED, AND RELATED SUBJECTS OF CONCERN.