

PARTS FOR MODEL TYPE EG-1Z OR EC-HZ

PI-1
(REV. C)

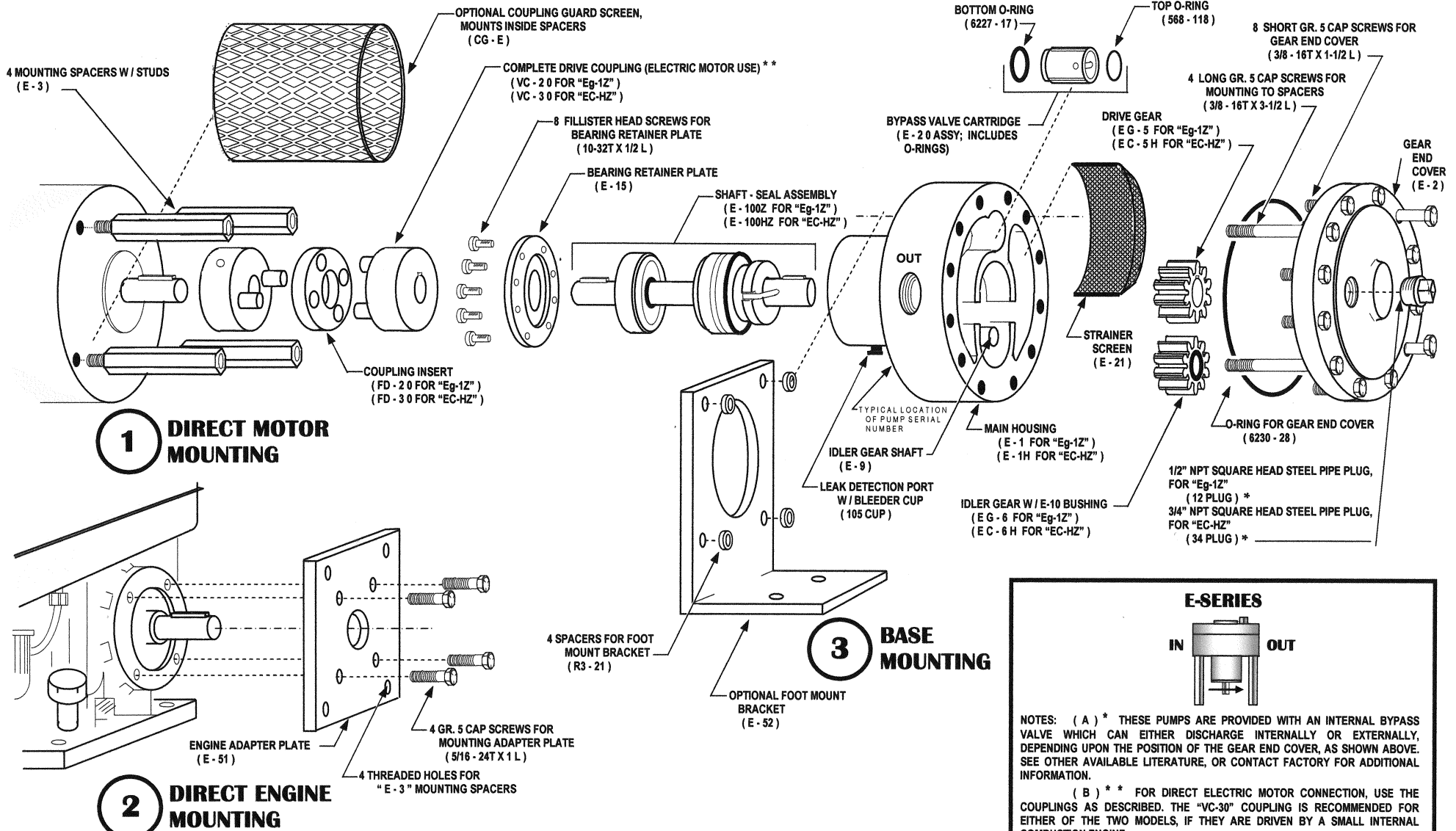

SMITH PRECISION PRODUCTS COMPANY

P.O. Box 276, Newbury Park, CA 91319 USA
 1299 Lawrence Drive, Newbury Park, CA 91320 USA
 Tel.: 805/498-6616 FAX: 805/499-2867

e-mail: INFO@smithpumps.com web: www.smithpumps.com

E-SERIES

IN OUT

NOTES: (A) * THESE PUMPS ARE PROVIDED WITH AN INTERNAL BYPASS VALVE WHICH CAN EITHER DISCHARGE INTERNALLY OR EXTERNALLY, DEPENDING UPON THE POSITION OF THE GEAR END COVER, AS SHOWN ABOVE. SEE OTHER AVAILABLE LITERATURE, OR CONTACT FACTORY FOR ADDITIONAL INFORMATION.

(B) ** FOR DIRECT ELECTRIC MOTOR CONNECTION, USE THE COUPLINGS AS DESCRIBED. THE "VC-30" COUPLING IS RECOMMENDED FOR EITHER OF THE TWO MODELS, IF THEY ARE DRIVEN BY A SMALL INTERNAL COMBUSTION ENGINE.

(C) THERE ARE TWO "E-SERIES" MODELS, NEITHER OF WHICH IS REVERSIBLE: THE "EC-HZ" WITH 1" NPT PORTS, AND THE "EG-1Z" WITH 3/4" NPT PORTS. TO INTERCHANGE THE POSITIONS OF THE INLET AND OUTLET, THE PUMPS MAY BE ROTATED 180°. IN MOST *INTERMITTENT DUTY*, LOW VOLUME BUTANE / PROPANE TRANSFER APPLICATIONS, THESE PUMPS CAN BE SUCCESSFULLY UTILIZED UP TO THEIR MAXIMUM DESIGN SPEED (3600 RPM). SEE APPROPRIATE LITERATURE, OR CONTACT FACTORY FOR ADDITIONAL INFORMATION ON THESE AND RELATED SUBJECTS OF CONCERN.