

SMITH BYPASS VALVES

OVERALL DIMENSIONS

MODEL NO.	SIZE	A	B	C
WW-120	1/2 x 1/2	1 5/8	5 1/6	1 3/4
WW-340	3/4 x 3/4	1 5/8	5 1/6	1 3/4
WW-100	1 x 1	1 7/8	5 5/8	2 5/8
WW-114	1 1/4 x 1 1/4	1 7/8	5 5/8	2 5/8
WW-112	1 1/2 x 1 1/2	1 7/8	5 5/8	2 5/8
WW-200	2 x 2	3	6 1/8	3 1/4
WW-212	2 1/2 x 2 1/2	3	6 1/8	3 1/4

All dimensions in inches.
All models FPT.

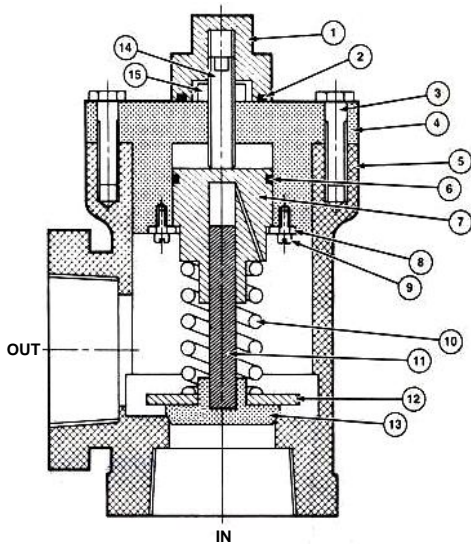
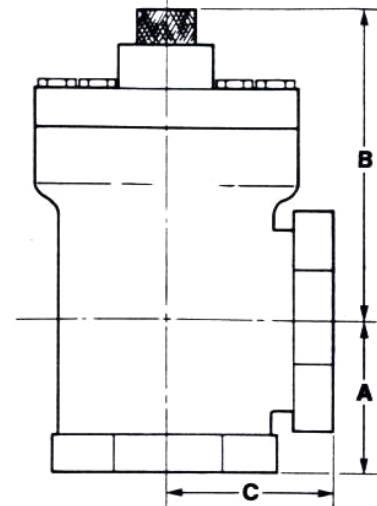

FOR MODELS WW-200 AND WW-212

- | | |
|------------------|---------------------------------|
| 1 VALVE CAP | 9 FILLISTER HEAD MACHINE SCREWS |
| 2 O-RING | 10 SPRING |
| 3 CAP SCREWS | 11 GUIDE PIN |
| 4 COVER | 12 VALVE PLATE |
| 5 MAIN HOUSING | 13 VALVE |
| 6 O-RING | 14 ADJUSTING SCREW |
| 7 SPRING COLLAR | 15 ADJUSTING SCREW NUT |
| 8 RETAINER PLATE | |

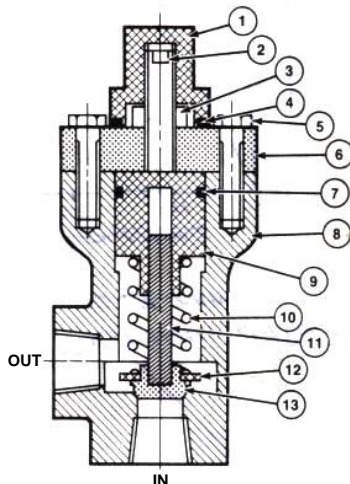

FOR MODELS WW-120, WW-340, WW-100, WW-114, WW-112

- | | |
|----------------------------|-----------------|
| 1 VALVE CAP | 8 MAIN HOUSING |
| 2 ADJUSTING SCREW | 9 SPRING COLLAR |
| 3 ADJUSTING SCREW NUT | 10 SPRING |
| 4 O-RING FOR VALVE CAP | 11 GUIDE PIN |
| 5 CAP SCREWS | 12 VALVE PLATE |
| 6 COVER | 13 VALVE |
| 7 O-RING FOR SPRING COLLAR | |



SMITH PRECISION PRODUCTS COMPANY

P.O. Box 276, Newbury Park, CA 91319 USA
 1299 Lawrence Drive, Newbury Park, CA 91320 USA
 Tel.: 805/498-6616 FAX: 805/499-2867
 e-mail: INFO@smithpumps.com web: www.smithpumps.com