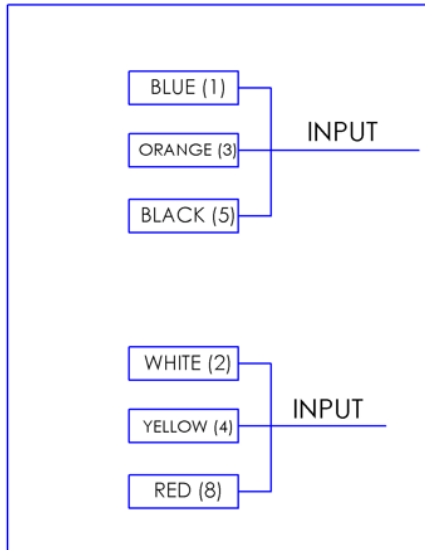
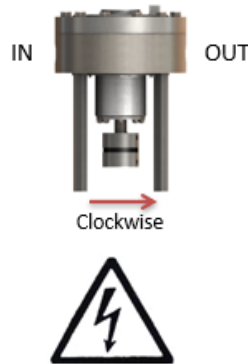
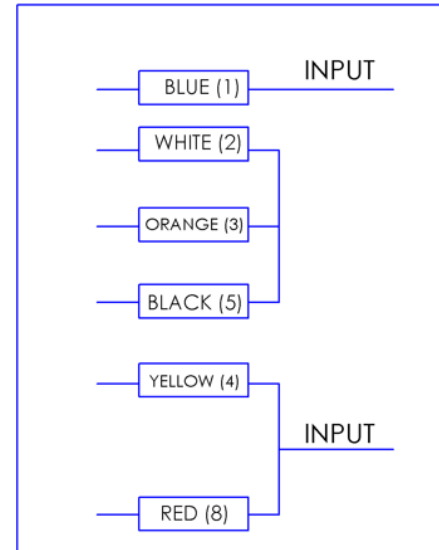

WIRING DIAGRAM FOR BALDOR/RELIANCE MOTOR Model EM-5ABB158 & EM-5ABB1
 1-1/2 HP, 3600 RPM, SINGLE PHASE, 115/208/230V, 60 HZ EXPLOSION PROOF,
 UL LISTED CLASS 1 GROUP D, 143TC Frame

EC-HZ, GC-1LZ
Clockwise rotation

115V

208/230V

MAKE SURE THE ELECTRIC MOTOR IS
 APPROPRIATELY GROUNDED USING
 SET-SCREW IN SCREWED CONDUIT BOX
 SCREWED ON TO MOTOR NIPPLE.
 SEPARATE WIRE NOT PROVIDED

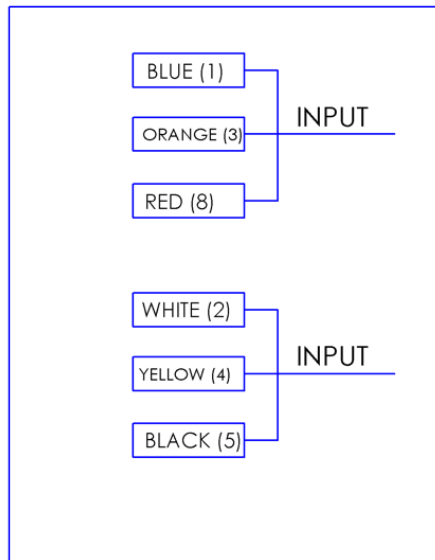
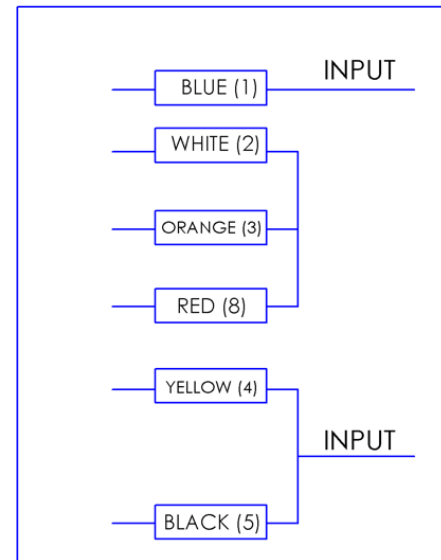
DW-HZ, MC-1Z
Counter-clockwise rotation

115V

208/230V

NOTE:
 TWO BROWN J-LEADS ARE FOR
 MOTOR THERMAL OVERLOAD DEVICE.
 CONNECT J LEADS TO MOTOR
 STARTER PILOT CIRCUIT

- **PUMP/MOTOR COMBINATIONS SHIPPED FROM FACTORY ARE ALWAYS WIRED FOR CORRECT ROTATION AND HIGH VOLTAGE (230V)**
- **INTERCHANGE THE 5 (BLACK) & 8 (RED) LEADS TO CHANGE ROTATION**

SMITH PRECISION PRODUCTS COMPANY

P.O. Box 276, Newbury Park, CA 91319 USA
 1299 Lawrence Drive, Newbury Park, CA 91320 USA
 Tel.: 805/498-6616 FAX: 805/499-2867
 e-mail: INFO@smithpumps.com **web: www.smithpumps.com**